

DeZURIK
COPEES-VULCAN
A unit of **SPX** Corporation

**SD SEVERE DUTY
CONTROL VALVES**

DeZURIK/COPEES-VULCAN



SD-1000 Control Valves

The SD-1000 valve is DeZURIK/Copes-Vulcan's premium severe duty and critical service control valve design.

While virtually identical in outward appearance to the DeZURIK/Copes-Vulcan legendarily rugged and dependable D-100 valve line which it replaces, the SD-1000 line is the next generation of control valves designed specifically for severe duty applications. It is the preferred style of valve for applications such as pump recirculation, feedwater control and feedwater start-up, flashing or cavitating service, critical pressure drop gas and steam service, and any potentially noisy or vibration-prone service. It is also widely used for nuclear "N" stamp and seismic applications.

The SD-1000 line incorporates a number of improvements such as:

- Quick disconnect between valve stem and actuator yoke on most models that greatly simplifies service and inspection.
- An extensive array of standard trims is available including many previously offered only as custom designs.
- Shorter lead times/quicker delivery of both entire valve assemblies and replacement parts.



Improvements such as these, coupled with DeZURIK/Copes-Vulcan's innovative yet sound engineering practices, and a reputation for building the best control valves possible, assures that the SD-1000 line is destined to become the new industry standard for severe duty and critical service applications.

For applications requiring pressure classes of 600 and below and where severe duty and critical service are neither anticipated nor required, DeZURIK/Copes-Vulcan's GS Series valves are an economical alternative. See Bulletin 1150 for additional details.

Description and Principle of Operation

SD-1000 valve assemblies feature a straight through, globe style body design with single web internal construction. The valve body is designed with high structural integrity, large interior flow passageways and a large capacity bowl to accommodate an extensive variety of trim designs while allowing maximum recovery within the valve. The massive amount of body and bonnet material utilized and the thick cross sectional areas allow the SD valve to withstand the most severe operational conditions.

The valve is available in sizes .75–20" (20–500mm) and ANSI pressure classes 150 through 4500 standard. Larger sizes are available as required. Typically of cast construction, all standard castable materials are available. When necessary, due to customer preference or technical requirements, forgings are utilized for both body and bonnet. Depending upon size and pressure class, ends are available as threaded, flanged or welded.

The most important sub-assembly of a control valve is the trim. It must control the fluid process, often under extremely high pressure drop conditions, without undue damage due to flashing, cavitation, wire drawing, noise vibration or instability. SD Series valves can be fitted with an extensive array of standard and high performance trims to meet most severe duty/critical service requirements. DeZURIK/Copes-Vulcan specialty trims such as Raven™, Hush™, Soft-Seated Hush, Tandem and GAD™ are readily available to meet the most severe applications. Additionally, custom engineered trims are supplied by DeZURIK/Copes-Vulcan as required.

All trims are of quick change design to assure ease of maintenance. Most are fully interchangeable between like sizes to ensure maximum flexibility and reduced inventory requirements.

A complete range of extremely rugged 1000 series pneumatic diaphragm actuators will meet practically any severe duty service including both nuclear and seismic requirements.

The SD-1000 design is in accordance with ANSI B16.1, B16.5, B16.11, B16.25, B16.34 and, when required, will comply with standards such as CAN 3 Z299.2, .3 and .4, ASME SEC.1, ASME SEC.3 B31.1 ETC.



Additional Body Styles



"A" Style
Cast Angle



"F" Style Forged
Straight-Thru
Globe



"3W" Style
Cast Body

RAVEN™ Trim

Raven trim incorporates a unique advanced design that is superb at limiting flowing velocities to low levels resulting in valves providing service that is quiet, non-cavitating and non-erosive.

Raven's low velocities are achieved through the use of trim cage made by bonding together a series of individual discs. Each disc has a pattern of carefully controlled orifices and channels with a multitude of sharp turns etched into its surface. As the trim's plug travels within the cage the fluid is throttled and forced to travel an extremely torturous path with each turn effecting a stage of pressure drop.

The combined effect of numerous narrow flow channels, each with many sharp turns and a continually expanding flow path, removes kinetic energy from the fluid while gradually lowering its pressure. In doing so, abrupt velocity increases that are the source of noise are avoided. The additional benefit for liquid flow is the elimination of cavitation and the damage it can do to a valve, its trim and the downstream piping.

By its very design Raven trim allows for many more stages of drop than conventional torturous path trims.

Superior to other velocity control trims, Raven, through the use of a consistent narrow wall design, typically is more efficient at passing flow or allowing more turns or stages of drop in a given valve size.

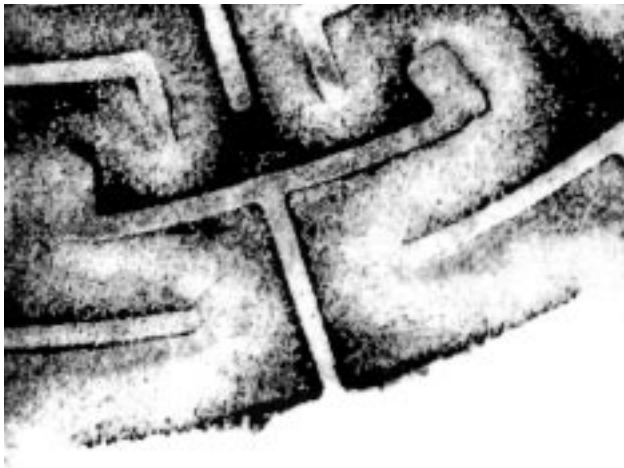

Actual gaseous flow through Raven trim as recorded in DeZURIK/Copes-Vulcan's Technical Center.

Most Raven trims contain multiple relief points in the flow path as a standard feature. These relief points allow entrained debris to clear the main fluid flow, or in the case of significant path blockage, they provide an effective bypass route for the fluid. With the benefits of the relief points, the actual fluid flow streams still remain virtually separate or discrete from each other for best velocity control.

By manufacturing the flow channels to extremely close tolerances, Raven's calculated or predicted versus actual pressure drops are significantly more accurate than competitors. Hence, velocities are more uniform throughout the entire trim, further guarding against noise, erosion and cavitation.

Ultimately, each Raven trim is specifically designed to provide the finest severe duty valve service by **Reducing and Attenuating Velocity, Erosion and Noise.**



Proven Superior Technology

Note the highly visible attachment phenomenon wherein the flow stream hugs or clings to each obstruction in its path, effectively taking the path of least resistance. Also, despite multiple relief points in the flow path it can be clearly seen that the fluid does not recombine with the Raven trim, rather the flow streams remain virtually separate or discrete from each other for best velocity control. Refer to Bulletin 1160 for detailed information.

HUSH® Trim

HUSH Trim is an advanced concept in control valve trim for high pressure-drop liquid, gas and steam applications.

It is a cage guided type trim that provides excellent control for compressible and noncompressible fluid applications by directing the flow through a series of staged pressure drops. This unique trim eliminates cavitation in liquid flow and provides multiple pressure breakdown for noise attenuation in critical pressure drop compressible fluid applications. Refer to Bulletin 1124 for detailed information.



GAD™ Trim

The DeZURIK/Copes-Vulcan Port Throttling GAD trim was developed to meet the rigorous requirements of feedwater startup control. Designed to give optimum flexibility in power operated control valves, the trim is available in double seat, balanced single seat, and tandem versions.

The GAD trim is equally suitable for use with steam and many other fluids. It has been successfully used on high pressure water applications involving pressure of up to 5075 psi (34970 kPa) and pressure differential of up to 3625 psi (24980 kPa). Refer to Bulletin 146 for detailed information.



Exclusive Soft Seated HUSH™ Trim

Soft Seated HUSH Trim is designed for new or replacement trim in DeZURIK/Copes-Vulcan valves as well as valves of other manufacturers. Any liquid control valve taking a pressure drop up to 5000 psi (34450 kPa) that spends more than 90% of the time in the closed position must use Soft Seated HUSH Trim to maintain zero leakage. Refer to Bulletin 142 for detailed information.

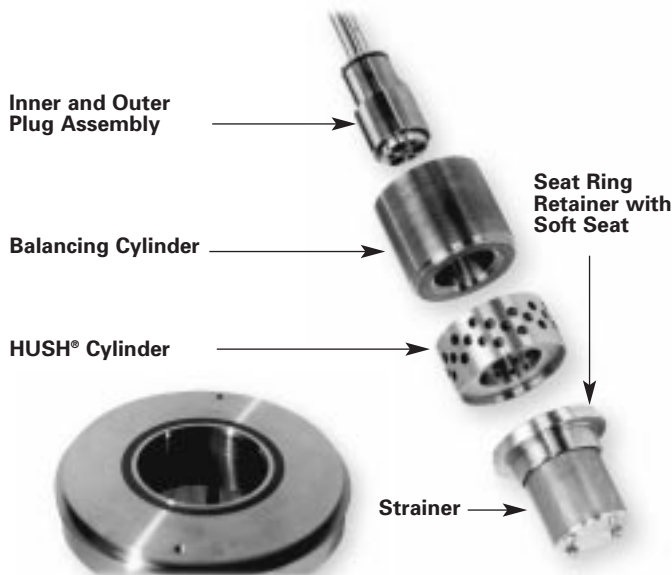

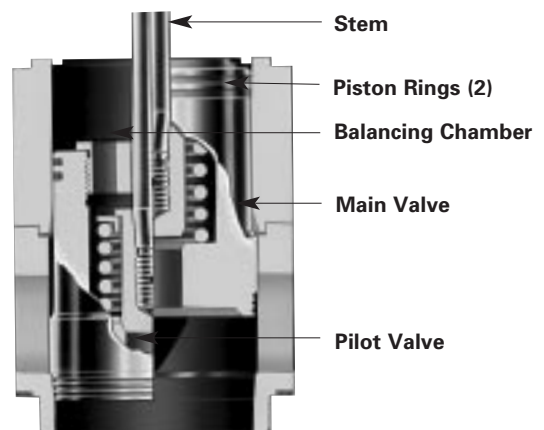

Tandem Trim

The Tandem Trim is designed primarily for high pressure differential applications where tight shutoff is essential. Such applications include steam and water pressure reduction, steam throttling to atmosphere or to a condenser, isolation, supercritical boiler startup and a variety of other uses in steam and water control systems. Refer to Bulletin 109 for detailed information.

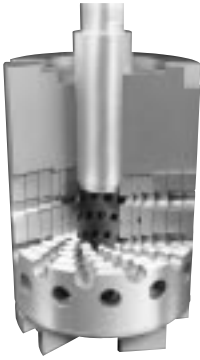

Trim Types

A wide variety of trims is available for SD-1000 Control Valves. They are designed to match virtually any severe duty/critical service operational requirement. All SD trims feature a quick-change design to reduce downtime for inspection, maintenance or change out, and most are cage guided, further ensuring smooth, accurate operation. The majority of the trim line is interchangeable between like sizes, and many reduced trims are also available as standard.

Trim Type	Raven™ Trim	HUSH™ Trim	Soft Seated HUSH™ Trim	Tandem Trim
				
Description/ Application	Raven is DeZURIK/Copes-Vulcan's top-of-the-line high performance specialty trim that offers a proven solution for those severe service applications where a true velocity control trim is the best or possibly the only answer. By limiting the fluid velocities inside the valve, Raven's stacked disc design precludes problems typically associated with high velocity such as erosion, noise, vibration and poor control. Every Raven trim is custom designed to meet the needs of the toughest liquid, steam and gas services in the power and process industries.	HUSH Trim (multiple stage) is a high performance specialty trim that is cage guided and provides excellent control for both compressible and noncompressible fluid applications. By directing the flow through a series of staged pressure drops, this unique trim eliminates cavitation in liquid flow and provides multiple pressure breakdown for noise attenuation in critical pressure drop compressible fluid application. It is designed for all valve sizes.	Soft seated Hush Trim (double plug) is a high performance specialty trim that is cage guided and designed to provide and maintain extremely tight shutoff for high pressure differential liquid applications. Typically applied to operating conditions that exhibit pressure drops in excess of 1800 psig (12400 kPag) that are to remain closed more than 25% of the time. It is the ideal trim for applications such as boiler feed pump recirculation, spray block valves and spray control valves.	Tandem Trim is a high performance specialty trim that is a cage guided, uniquely balanced port throttling trim designed to solve difficult high temperature, high pressure differential applications that would require oversized, expensive actuators if more standard trims were utilized. Due to the relatively small pilot plug designed into the tandem trim, tight shutoff of up to Class V can easily be achieved with a moderately sized, economically priced actuator. It is available for valves 4" (100mm) and larger.
Standard FCI 70-2/ANSI Rated Seat Leakage	Class IV standard Class V optional *Class VI optional	Class IV standard Class V optional *Class VI optional	Class VI standard	Class IV standard Class V optional
Standard Trim Characteristic	Linear standard, Specials optional	Linear standard, Specials optional	Linear standard, Specials optional	Special
Typical Flow Direction	Under the seat Over the Seat	Under the seat	Under the seat	Over the seat Under the seat
Maximum Rangeability	100:1	40-75:1	10-25:1	25-50:1

* Class VI requires use of soft seat.

The trims shown in this bulletin represent the more common selections available. Additional standard, special and custom engineered trims can be supplied as required.

Standard stocked trim materials are 300 series and 400 series stainless steel. Other materials are available on special order.

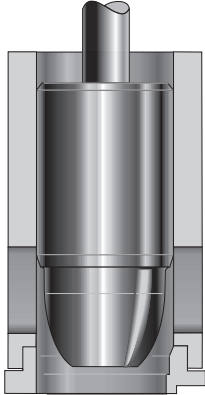
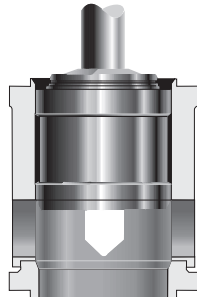
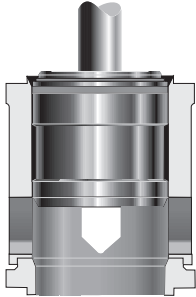
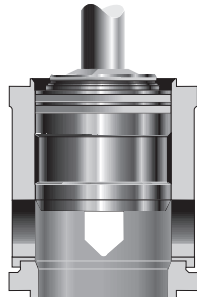
<p style="text-align: center;">GAD Trim</p> 	<p style="text-align: center;">Unbalanced Single Seat Plug Throttling</p> 	<p style="text-align: center;">Unbalanced Single Seat Port Throttling</p> 	<p style="text-align: center;">Balanced Single Seat Port Throttling</p> 	<p style="text-align: center;">Balanced Single Seat Port Throttling (Hi-Temp)</p> 
<p>GAD Trim is a high performance specialty trim that is cage guided and engineered to meet the rigorous requirements of feedwater control and feedwater startup control. Designed to give optimum flexibility in automated control valves, this trim is available in double seat, balanced single seat, tandem plug and one-stage Hush versions. GAD Trim is equally suitable for use with steam and many other fluids. It has been successfully used on high pressure water applications involving pressure of 5075 psi (34970 kPa) and pressure differential of up to 3625 psi (24980 kPa). It is available for valves 2" (50mm) and larger.</p>	<p>This trim style is a general purpose cage guided trim for on/off or modulating control. It is designed for low to moderate pressure drop applications. The solid plug has a contour on its lower end that provides varying flow area with lift, thus regulating the flow. It can be used with a wide variety of non-abrasive/non-adhesive compressible and noncompressible fluids. Standard trim for valve sizes 1.5" (40mm) and smaller.</p>	<p>This trim style is a general service cage guided trim for on/off or modulating control where moderate flow rates exist along with low differential pressures. The unbalanced single seat plug modulates flow by uncovering ports in the cage. The cage porting produces the pressure drop or flow control. This trim can be used in most non-abrasive/non-adhesive compressible and noncompressible fluids.</p>	<p>This trim style is a general purpose cage guided trim for on/off or modulating control suitable for use in most non-abrasive/non-adhesive compressible and noncompressible fluid services. The balanced plug design reduces actuator force requirements thus permitting the use of smaller, less expensive actuators while maintaining tight shutoff capability. It is designed for valves 2" (50mm) and larger and is a standard offering when the service temperature does not exceed the 400°-500°F (204°- 260°C) range, relative to pressure.</p>	<p>This general purpose cage guided trim is virtually identical in all respects to the balanced single seat port throttling trim except that piston rings are used in lieu of the elastomeric seal on the trim's plug. While the piston rings do limit the leakage rate to ANSI Class III, this trim is a viable option when a balanced plug is desirable and when temperatures of the fluid exceed 500°F (260°C). It is for valve sizes 2" (50mm) and larger.</p>
<p style="text-align: center;">Class III-IV Depending upon design selected</p>	<p style="text-align: center;">Class IV standard Class V optional</p>	<p style="text-align: center;">Class IV standard Class V optional</p>	<p style="text-align: center;">Class IV standard Class V optional *Class VI optional</p>	<p style="text-align: center;">Class IV standard</p>
<p style="text-align: center;">Modified parabolic, linear, equal percentage. All available as standard</p>	<p style="text-align: center;">Modified parabolic, linear, equal percentage</p>	<p style="text-align: center;">Modified parabolic, linear, equal percentage</p>	<p style="text-align: center;">Modified parabolic, linear, equal percentage</p>	<p style="text-align: center;">Modified parabolic, linear, equal percentage</p>
<p style="text-align: center;">Over the seat</p>	<p style="text-align: center;">Under the seat</p>	<p style="text-align: center;">Under the seat</p>	<p style="text-align: center;">Over the seat</p>	<p style="text-align: center;">Over the seat</p>
<p style="text-align: center;">50:1</p>	<p style="text-align: center;">50:1</p>	<p style="text-align: center;">35-50:1</p>	<p style="text-align: center;">35-50:1</p>	<p style="text-align: center;">35-50:1</p>

* Class VI requires use of soft seat.

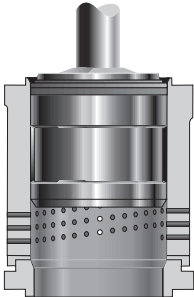
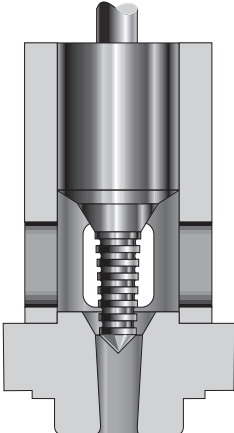
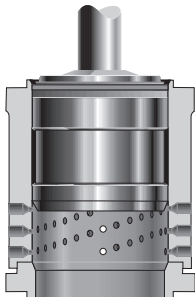
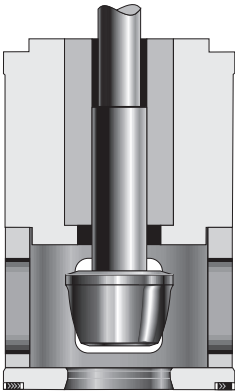
<p style="text-align: center;">One Stage Hush®</p> 	<p style="text-align: center;">Cascade</p> 	<p style="text-align: center;">CAV B9®</p> 	<p style="text-align: center;">Top Guided</p> 
<p>One Stage Hush trim is a specialty trim designed to reduce noise associated with compressible fluids as well as to reduce the undesirable effects of flashing and cavitation that would occur with most single pressure drop trims. The Hush cage consists of a single cylinder with a large number of radially drilled orifices. The fluid exits the orifices as low energy jets resulting in significant reductions in noise or erosion. Although numerous standard designs are available, One Stage Hush is often custom engineered to provide various flow characteristics or optimal performance under specific operating conditions.</p>	<p>This trim style is a cage guided plug throttling trim designed primarily for high pressure drop water applications where cavitation, vibration and excessive wear occur with conventional trims. The tapered plug fits into a cage and seat with a matching taper, thus small changes in flow area occur with respect to plug travel resulting in extremely high rangeability. The labyrinth grooves machined into the plug's taper create a series of orifices which reduces the total pressure drop in a series of stages. It is especially suited to applications where small flow rates must be controlled accurately.</p>	<p>CAV B9 trim can be applied in liquid service where low level cavitation is evident. By utilizing flow over the seat, the radially step-drilled cage design reduces the effects of cavitation along with the associated noise and erosion problems by forcing the cavitation to occur in the center of the cage, away from all metal surfaces. In instances where flashing conditions are experienced, flow under the seat is employed with the multitude of small ports reducing both noise and erosion. Although numerous standard designs are available, the trim can be custom designed to provide various flow characteristics or optimal performance under specific flow conditions. It is available for valves 2" (50mm) and larger.</p>	<p>This non-cage guided trim is designed for use with a wide variety of process applications involving corrosive, erosive and viscous line fluids and many steam and water applications. It is ideal for control applications where a maximum of free flow area is desired. The trim is unbalanced, single seat, plug throttling with the plug guided by a large diameter metal or teflon insert along the lower stem area. This guiding method ensures quiet, stable, vibration free operation with pressure drops limited to 600 psi (4130 kPa) under operating conditions. Pressure drop should also be limited to avoid cavitation or flashing. It is for valve sizes 4" (100mm) and smaller.</p>
<p>Class IV standard Class V optional *Class VI optional</p>	<p>Class IV standard Class V optional</p>	<p>Class IV standard Class V optional *Class VI optional</p>	<p>Class IV standard Class V optional *Class VI optional</p>
<p>Linear standard Specials optional</p>	<p>Special</p>	<p>Linear standard Specials optional</p>	<p>Equal percentage, linear</p>
<p>Under the seat Over the seat</p>	<p>Under the seat</p>	<p>Under the seat (for flashing) Over the seat (for cavitation)</p>	<p>Under the seat</p>
<p>35-100:1</p>	<p>200:1</p>	<p>35-100:1</p>	<p>25:1</p>

* Class VI requires use of soft seat.

Actuators

Model 1000 Actuators Pneumatic Diaphragm — Spring Opposed

Designed specifically for severe duty service, model 1000 actuators can be used in any application where shock and/or vibration are anticipated, or where seismic analysis is required. They are available with 60, 100, 160, 260 and 400 in² (390, 645, 1030, 1680 and 2580 cm²) of effective diaphragm area in both the direct and reverse acting mode. All models are available with manually operated override wheels.

To illustrate how the actuator transmits force, the shaded areas shown in the diagrams below will move during the direct and reverse acting modes. (Note the position of the diaphragm plate in each case.)

Conversion of the actuator from direct to reverse acting is accomplished simply by unfastening the diaphragm base from the frame and rotating it 90° until it is positioned above the threaded holes in the yoke. The actuator can be returned to the direct acting mode by reversing the procedure.



Direct Acting

Reverse Acting

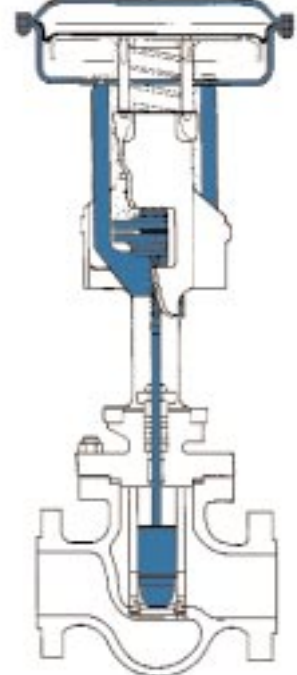
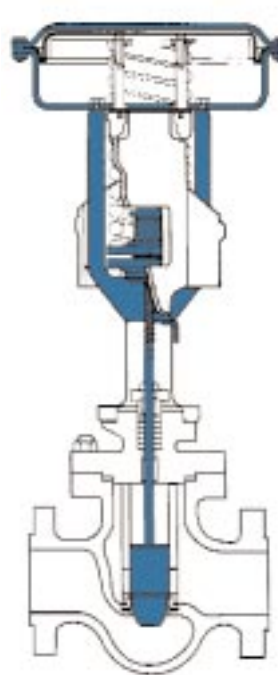
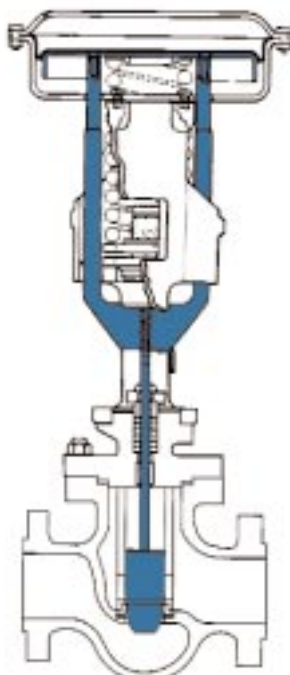
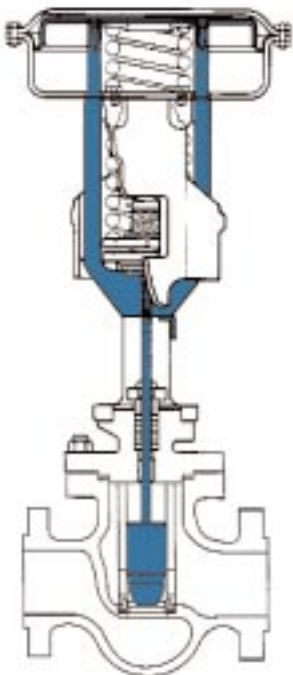

Valve Open

Valve Closed

Valve Closed

Valve Open

Actuators

The SD-700 Valve Assembly

The SD-700 valve assembly is comprised of an SD valve body, bonnet and trim with the 700 series actuator. In those instances where an SD valve (i.e. body, bonnet, trim, etc.) is necessary, but the use of the heavy duty, 1000 style actuator is not needed, the more economical 700 style operator can be utilized.

Series 700 actuators are pneumatic diaphragm operators that have spring return in both direct and reverse acting styles, offering fail-open and fail-closed modes respectively. The pressed steel diaphragm case construction along with the nylon reinforced Buna N rubber diaphragm permits a maximum allowable air supply pressure of 80 psig (550 kPag). This pre-formed diaphragm provides a constant effective area throughout the full extent of travel. With effective diaphragm areas ranging from 60–160 in² (385–1030 cm²), Series 700 actuators can provide the necessary stem force to meet many operating requirements.



Model 1000-260 Actuator

This actuator provides 260 in² (1680cm²) of effective diaphragm area and is offered with either direct or reverse action. As a variation of the 1000 style, the 1000-260 actuator has a number of features.

- Heavy duty, one-piece frame
- Large assortment of springs to cover a wide range of applications
- High thrust and long travel capability
- Optional handwheel activated hydraulic override units

Model 200 Piston Actuators

When necessitated by travel or thrust requirements, model 200 pneumatic actuators are supplied. Contact DeZURIK/Copes-Vulcan for details and dimensions.

Series 300 Electro/Hydraulic Actuators

Electro/mechanical or electro/hydraulic actuators are available to meet specified operations. Contact DeZURIK/Copes-Vulcan for details.

Side Mounted Handwheel

Side mounted handwheels are available for the Series 700 actuator. Contact DeZURIK/Copes-Vulcan for details and dimensions.



Series 800 Manual Operated Actuators

DeZURIK/Copes-Vulcan offers handwheel operated actuators for applications where an automated valve is not required or where compressed air service is unavailable. Series 800 actuators are suitable for both on/off and modulating service.

Accessories

Typical valve-mounted accessories such as positioners, air filter regulators, solenoids, and limit switches are available as standard offerings.

Dimensions

SD Valve Body/Bonnet Assembly

Flanged Ends

Valve Size	Class 150			Class 300			Class 400			Class 600		
	A	B	C	A	B	C	A	B	C	A	B	C
.75" 20mm	7.25" 184mm	7.00" 178mm	2.56" 65mm	7.62" 194mm	7.00" 178mm	2.56" 65mm	8.12" 206mm	7.00" 178mm	2.56" 65mm	8.12" 206mm	7.00" 178mm	2.56" 65mm
1" 25mm	7.25" 184mm	7.00" 182mm	2.56" 65mm	7.75" 197mm	7.00" 178mm	2.56" 65mm	8.25" 210mm	7.00" 178mm	2.56" 65mm	8.25" 210mm	7.00" 178mm	2.56" 65mm
1.5" 40mm	8.75" 222mm	7.25" 184mm	2.88" 73mm	9.25" 235mm	7.25" 184mm	2.88" 73mm	9.88" 251mm	7.25" 184mm	2.88" 73mm	9.88" 251mm	7.25" 184mm	2.88" 73mm
2" 50mm	10.00" 254mm	7.34" 186mm	3.50" 89mm	10.50" 267mm	7.34" 186mm	3.50" 89mm	11.25" 286mm	7.34" 186mm	3.56" 90mm	11.25" 286mm	7.34" 186mm	3.56" 90mm
2.5" 60mm	10.88" 276mm	9.31" 236mm	4.06" 103mm	11.50" 292mm	9.31" 236mm	4.06" 103mm	12.25" 311mm	9.31" 236mm	4.19" 106mm	12.25" 311mm	9.31" 236mm	4.19" 106mm
3" 75mm	11.75" 298mm	9.72" 247mm	4.44" 113mm	12.50" 318mm	9.72" 247mm	4.44" 113mm	13.25" 337mm	9.72" 247mm	4.50" 114mm	13.25" 337mm	9.72" 247mm	4.50" 114mm
4" 100mm	13.88" 353mm	9.91" 252mm	5.38" 137mm	14.50" 368mm	9.91" 252mm	5.38" 137mm	15.25" 387mm	9.91" 252mm	5.56" 141mm	15.50" 394mm	9.91" 252mm	5.56" 141mm
6" 150mm	17.75" 451mm	12.16" 309mm	7.69" 195mm	18.62" 473mm	12.16" 309mm	7.69" 195mm	19.50" 495mm	12.16" 309mm	7.88" 200mm	20.00" 508mm	12.16" 309mm	7.88" 200mm
8" 200mm	21.38" 543mm	13.31" 338mm	10.25" 260mm	22.38" 568mm	13.31" 338mm	10.25" 260mm	23.38" 594mm	13.31" 338mm	10.56" 268mm	24.00" 610mm	13.31" 338mm	10.56" 268mm
10" 250mm	29.38" 746mm	19.00" 482mm	13.00" 330mm	30.75" 781mm	19.00" 482mm	13.00" 330mm	31.75" 806mm	19.00" 482mm	13.00" 330mm	32.50" 826mm	19.00" 482mm	13.00" 335mm
12" 300mm	35.25" 895mm	23.06" 586mm	15.00" 381mm	36.75" 933mm	23.06" 586mm	15.00" 381mm	37.75" 959mm	23.06" 586mm	15.19" 386mm	38.50" 978mm	23.06" 586mm	15.19" 386mm

Flanged Ends (Cont.)

Valve Size	Class 900			Class 1500			Class 2500		
	A	B	C	A	B	C	A	B	C
.75" 20mm	11.12" 282mm	10.00" 254mm	2.50" 64mm	11.12" 282mm	10.00" 254mm	2.50" 64mm	12.12" 308mm	10.00" 254mm	2.50" 64mm
1" 25mm	11.50" 292mm	10.00" 254mm	2.75" 70mm	11.50" 292mm	10.00" 254mm	2.75" 70mm	12.50" 318mm	10.00" 254mm	2.75" 70mm
1.5" 40mm	13.12" 333mm	10.15" 258mm	3.00" 76mm	13.12" 333mm	10.15" 258mm	3.00" 76mm	14.12" 359mm	10.15" 258mm	3.25" 83mm
2" 50mm	14.75" 375mm	10.15" 258mm	3.75" 95mm	14.75" 375mm	10.15" 258mm	3.75" 95mm	15.75" 400mm	10.15" 258mm	3.88" 99mm
2.5" 60mm	16.12" 409mm	12.15" 309mm	4.44" 113mm	16.12" 409mm	12.15" 309mm	4.44" 113mm	17.38" 441mm	12.15" 309mm	4.62" 117mm
3" 75mm	17.38" 441mm	12.47" 317mm	4.56" 116mm	18.12" 460mm	12.47" 317mm	4.81" 122mm	19.62" 498mm	12.47" 317mm	5.56" 141mm
4" 100mm	20.62" 524mm	13.56" 344mm	6.12" 155mm	21.38" 543mm	13.56" 344mm	6.12" 155mm	23.12" 587mm	13.56" 344mm	6.50" 165mm
6" 150mm	23.62" 600mm	14.81" 376mm	8.12" 206mm	27.25" 692mm	14.81" 376mm	8.94" 227mm	32.25" 819mm	14.81" 376mm	9.44" 240mm
8" 200mm	30.75" 781mm	16.06" 408mm	10.82" 275mm	33.00" 838mm	16.06" 408mm	11.25" 286mm	40.50" 1029mm	16.06" 408mm	11.94" 303mm
10" 250mm	34.00" 864mm	22.06" 560mm	13.00" 324mm	42.00" 1067mm	22.06" 560mm	14.00" 356mm	54.00" 1372mm	22.06" 560mm	14.88" 378mm
12" 300mm	40.00" 1016mm	26.06" 662mm	15.56" 395mm	48.00" 1219mm	26.06" 662mm	15.31" 389mm	62.00" 1575mm	26.06" 662mm	16.38" 416mm

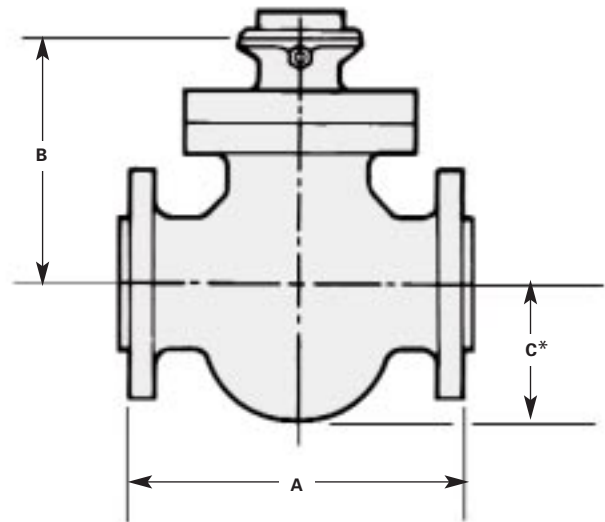

*Radius of flange may exceed C.

Dimensions

SD Valve Body/Bonnet Assembly (Cont.)

Weld Ends and Threaded Ends (For 2" (50mm) and Smaller)

Valve Size	Class 150			Class 300			Class 400			Class 600		
	A	B	C	A	B	C	A	B	C	A	B	C
.75" 20mm	7.75" 197mm	7.00" 178mm	2.56" 65mm	7.75" 197mm	7.00" 178mm	2.56" 65mm	7.75" 197mm	7.00" 178mm	2.56" 65mm	7.75" 197mm	7.00" 178mm	2.56" 65mm
1" 25mm	7.75" 197mm	7.00" 178mm	2.56" 65mm	7.75" 197mm	7.00" 178mm	2.56" 65mm	7.75" 197mm	7.00" 178mm	2.56" 65mm	7.75" 197mm	7.00" 178mm	2.56" 65mm
1.5" 40mm	9.25" 235mm	7.25" 184mm	2.88" 73mm	9.25" 235mm	7.25" 184mm	2.88" 73mm	9.25" 235mm	7.25" 184mm	2.88" 73mm	9.25" 235mm	7.25" 184mm	2.88" 73mm
2" 50mm	10.50" 267mm	7.34" 186mm	3.50" 89mm	10.50" 267mm	7.34" 186mm	3.50" 89mm	10.50" 267mm	7.34" 186mm	3.56" 90mm	10.50" 267mm	7.34" 186mm	3.56" 89mm
2.5" 60mm	11.50" 292mm	9.31" 236mm	4.06" 103mm	11.50" 292mm	9.31" 236mm	4.06" 103mm	11.50" 292mm	9.31" 236mm	4.19" 106mm	11.50" 292mm	9.31" 236mm	4.19" 103mm
3" 75mm	12.50" 318mm	9.72" 247mm	4.44" 113mm	12.50" 318mm	9.72" 247mm	4.44" 113mm	12.50" 318mm	9.72" 247mm	4.50" 114mm	12.50" 318mm	9.72" 247mm	4.50" 113mm
4" 100mm	14.50" 368mm	9.91" 252mm	5.38" 137mm	14.50" 368mm	9.91" 252mm	5.38" 137mm	14.50" 368mm	9.91" 252mm	5.56" 141mm	14.50" 368mm	9.91" 252mm	5.56" 137mm
6" 150mm	20.00" 508mm	12.16" 309mm	7.69" 195mm	20.00" 508mm	12.16" 309mm	7.69" 195mm	20.00" 508mm	12.16" 309mm	7.88" 200mm	20.00" 508mm	12.16" 309mm	7.88" 195mm
8" 200mm	24.00" 610mm	13.31" 338mm	10.25" 260mm	24.00" 610mm	13.31" 338mm	10.25" 260mm	24.00" 610mm	13.31" 338mm	10.56" 260mm	24.00" 610mm	13.31" 338mm	10.56" 260mm
10" 250mm	30.00" 762mm	19.00" 482mm	13.00" 330mm	30.00" 762mm	19.00" 482mm	13.00" 330mm	30.00" 762mm	19.00" 482mm	13.00" 330mm	30.00" 762mm	19.00" 482mm	13.00" 335mm
12" 300mm	36.00" 914mm	23.06" 586mm	15.00" 381mm	36.00" 914mm	23.06" 586mm	15.00" 381mm	36.00" 914mm	23.06" 586mm	15.19" 386mm	36.00" 914mm	23.06" 586mm	15.19" 386mm

Weld Ends and Threaded Ends (Cont.)

Valve Size	Class 900			Class 1500			Class 2500		
	A	B	C	A	B	C	A	B	C
.75" 20mm	7.62" 194mm	10.00" 254mm	2.50" 64mm	7.62" 194mm	10.00" 254mm	2.50" 64mm	8.50" 216mm	10.00" 254mm	2.50" 64mm
1" 25mm	7.75" 197mm	10.00" 254mm	2.75" 70mm	7.75" 197mm	10.00" 254mm	2.75" 70mm	8.50" 216mm	10.00" 254mm	2.75" 70mm
1.5" 40mm	9.25" 235mm	10.15" 258mm	3.00" 76mm	9.25" 235mm	10.15" 258mm	3.00" 76mm	10.25" 260mm	10.15" 258mm	3.25" 83mm
2" 50mm	11.50" 292mm	10.15" 258mm	3.75" 95mm	11.50" 292mm	10.15" 258mm	3.75" 95mm	12.50" 318mm	10.15" 258mm	3.88" 99mm
2.5" 60mm	11.50" 292mm	12.15" 309mm	4.44" 113mm	11.50" 292mm	12.15" 309mm	4.44" 113mm	12.50" 318mm	12.15" 309mm	4.62" 117mm
3" 75mm	12.50" 318mm	12.47" 317mm	4.56" 116mm	12.50" 318mm	12.47" 317mm	4.81" 122mm	15.00" 381mm	12.47" 317mm	5.56" 141mm
4" 100mm	14.50" 368mm	13.56" 344mm	6.12" 155mm	14.50" 368mm	13.56" 344mm	6.12" 155mm	16.00" 406mm	13.56" 344mm	6.50" 165mm
6" 150mm	20.00" 508mm	14.81" 376mm	8.12" 206mm	22.00" 559mm	14.81" 376mm	8.94" 227mm	24.00" 610mm	14.81" 376mm	9.44" 240mm
8" 200mm	24.00" 610mm	16.06" 408mm	10.82" 275mm	27.00" 686mm	16.06" 408mm	11.25" 286mm	30.00" 762mm	16.06" 408mm	11.94" 303mm
10" 250mm	30.00" 762mm	22.06" 560mm	13.00" 342mm	34.00" 864mm	22.06" 560mm	14.00" 356mm	40.00" 1016mm	22.06" 560mm	14.88" 378mm
12" 300mm	36.00" 914mm	26.06" 662mm	15.56" 395mm	38.00" 965mm	26.06" 662mm	15.31" 389mm	44.00" 1118mm	26.06" 662mm	16.38" 416mm

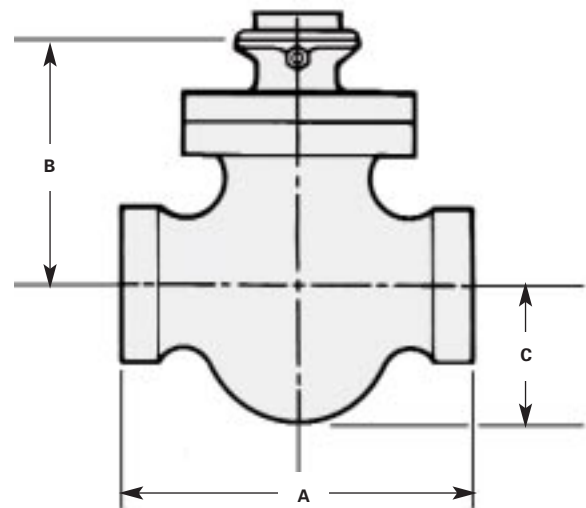

Note: The SD-style bonnet is easily adaptable to all sizes and types of pneumatic, electric and hydraulic actuators.

Series 1000 Actuators

Actuator Model	D	E	F*	G**	H	I
1000-60	17.25" 438mm	11.50" 292mm	1.50" 38mm	8.50" 216mm	10.00" 254mm	7.75" 197mm
1000-100	25.56" 649mm	15.12" 383mm	3.50" 89mm	11.25" 286mm	18.00" 457mm	7.75" 197mm
1000-160	30.88" 784mm	18.00" 457mm	3.50" 89mm	11.25" 286mm	18.00" 457mm	7.75" 197mm
1000-400	47.25" 1200mm	27.50" 698mm	4.50" 114mm	13.00" 330mm	20.00" 508mm	20.75" 527mm

*Clearance required for reverse action

** Clearance required for actuator removal

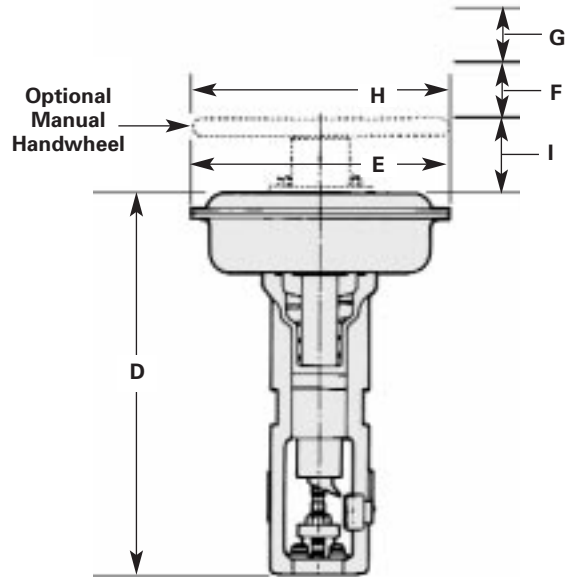

Series 700 Actuators (Shown with Optional Top-Mounted Handwheel)

Direct Acting (Spring-to-Open)

Actuator Size	60	100	160	160L
L	20.50" 521mm	28.12" 714mm	32.31" 821mm	39.75" 1010mm
M	11.50" 292mm	15.12" 384mm	18.00" 457mm	18.00" 457mm
N	7.56" 192mm	9.38" 238mm	9.31" 236mm	11.81" 300mm
O	5.81" 148mm	9.44" 240mm	9.50" 241mm	15.19" 386mm
P	10.00" 254mm	18.00" 457mm	18.00" 457mm	18.00" 457mm

Reverse Acting (Spring-to-Close)

Actuator Size	60	100	160	160L
L	21.09" 536mm	28.06" 713mm	32.38" 822mm	40.81" 1037mm
M	11.50" 292mm	15.12" 384mm	18.00" 457mm	18.00" 457mm
N	6.50" 165mm	6.50" 165mm	6.25" 159mm	6.38" 162mm
O	6.72" 171mm	11.38" 289mm	11.56" 294mm	17.19" 437mm
P	10.00" 254mm	18.00" 457mm	18.00" 457mm	18.00" 457mm

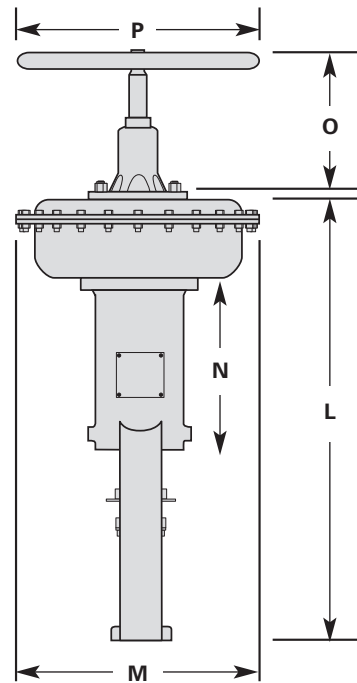

Nuclear Control Valves

DeZURIK/Copes-Vulcan Nuclear Control Valves are subjected to the most stringent quality assurance tests and inspections.

DeZURIK/Copes-Vulcan's quality performance dates back nearly a century when we began producing fine quality valves. Our 40-year nuclear experience has been in light water, heavy water, gas cooled and liquid sodium cooled reactors for commercial and military applications. Every valve destined for nuclear service is subjected to the most stringent quality assurance measures and inspections for maximum reliability and long, trouble-free service. Every valve meets applicable ASME Code and IEEE requirements.

DeZURIK/Copes-Vulcan is proud of its reputation as one of the leading worldwide producers of nuclear control valves. It's all part of our commitment to helping utilities produce safe, efficient nuclear power.

DeZURIK/Copes-Vulcan valves are designed in accordance with ANSI B16.34 with materials conforming to ASTM standards. DeZURIK/Copes-Vulcan valve assemblies meet requirements of ASME section III and IEEE standards 323, 344 and 382 for nuclear power plant service. DeZURIK/Copes-Vulcan maintains the ASME "N" and "NPT" stamp codes authorization.



Sales and Service

DeZURIK/Copes-Vulcan representatives are located in major cities throughout the world. For the name of the representative nearest you, contact:

Web Site: www.dezurikcopesvulcan.com **E-Mail:** info@dezurikcopesvulcan.com

DeZURIK/COPEs-VULCAN - SARTELL

250 Riverside Ave. N.
Sartell, Minnesota 56377-1743
Telephone: 320-259-2000
Fax: 320-259-2227

DeZURIK/COPEs-VULCAN - LAKE CITY

9843 Martin Ave.
P.O. Box 577
Lake City, PA 16423
Telephone: 814-774-1500
Fax: 814-774-1681

DeZURIK/COPEs-VULCAN of CANADA, LTD.

385 Franklin Blvd., P.O. Box 1300
Cambridge, Ontario, Canada N1R 5V5
Telephone: 519-621-8980
Fax: 519-621-3006

DeZURIK/COPEs-VULCAN - MEXICO

Nueva Jersey 4331
Fracc. Industrial Lincoln
Monterrey NL CP64310 Mexico
Telephone: 52-83-707164/5026
Fax: 52-83-713004

DeZURIK/COPEs-VULCAN - UNITED KINGDOM

Road Two, Industrial Estate
Winsford, Cheshire CW7 3QL
United Kingdom
Telephone: +44 1606 552041
Fax: +44 1606 552700

DeZURIK/COPEs-VULCAN - SOUTH CHINA

General Signal China Limited
1/F, No. 18, 485 Guiping Road
Caohejing Hi-Tech Park
Shanghai - 200233 China
Telephone: 86-21-64853018
Fax: 86-21-64852438

DeZURIK/COPEs-VULCAN - SINGAPORE

31 Kaki Bukit Road 3
#02-04, Techlink
Singapore 417818
Telephone: 65-547-2390
Fax: 65-842-7578

DeZURIK/COPEs-VULCAN - INDIA

220, Midas, Sahar Plaza
Sir M. V. Road, Andheri (E)
Mumbai - 400059
Telephone: 91-22-838-5857
Fax: 91-22-838-5895



DeZURIK/Copes-Vulcan reserves the right to incorporate our latest design and material changes without notice or obligation. Design features, materials of construction and dimensional data, as described in this bulletin, are provided for your information only and should not be relied upon unless confirmed in writing by DeZURIK/Copes-Vulcan. Certified drawings are available upon request.