

# Reineke



**Ein Unternehmen mit Tradition und Zukunft**  
**A company with tradition and a future**

**Produktinformation für Gasmessgeräte**  
**Product information for Gas Analysers**

**ISO 9001  
Qualität**



D-44807 Bochum · Von-Ebner-Eschenbach-Str. 5  
Postfach 102029 · D-44720 Bochum/Germany

## Reineke

Telefon 02 34 / 95 95-0 · Telefax 02 34 / 95 95-200  
e-mail: [reinekefuchs@t-online.de](mailto:reinekefuchs@t-online.de)

Meß- und Regeltechnik GmbH

# Reineke



**Ein Unternehmen mit Tradition und Zukunft**  
**A company with tradition and a future**

**Gasmessgerät für Wobbe-Index, Heizwert, Wärmefluss**  
**Gasmeasuring device for Wobbe-Index, Net Calorific value, Energy (heat) flow**

**ISO 9001  
Qualität**



D-44807 Bochum · Von-Ebner-Eschenbach-Str. 5  
Internet: [www.reineke-online.com](http://www.reineke-online.com)

## Reineke

Meß- und Regeltechnik GmbH

Telefon 02 34 / 95 95-0 · Telefax 02 34 / 95 95-200  
e-mail: [reinekefuchs@t-online.de](mailto:reinekefuchs@t-online.de)

## Technische Daten

<b>Messgerätetyp</b>	WI
<b>Messgas</b>	alle brennbaren Gase
<b>Messgröße</b>	Heizwert oder Wobbe-Index oder Wärmefluss
<b>Messbereich</b>	frei wählbar (wird werksseitig eingestellt) 50-100 % vom Messbereichsendwert z. B.: 50-100 (MJ/m <sup>3</sup> )
<b>Einheit</b>	frei wählbar (wird werksseitig eingestellt) MJ/m <sup>3</sup> * kWh/m <sup>3</sup> * Mcal/m <sup>3</sup>
<b>Ausgangssignal</b>	◆ 0 ... 20 mA (Bürde: ≤ 500 Ω) ◆ 4 ... 20 mA (Bürde: ≤ 500 Ω)
<b>Digitalanzeige</b>	3 1/2 stelliges LE-Display
<b>Zeitverhalten</b>	◆ Ansprechzeit: 3 s ◆ T <sub>50</sub> -Zeit: 8 s ◆ T <sub>90</sub> -Zeit: ~30 s nach Eintritt des Messgases in das Messgerät in Abhängigkeit vom gewählten Messbereich ◆ Anwärmzeit: 30 min
<b>Messgenauigkeit</b>	◆ Wobbe-Index ± 1 % ◆ Wärmefluss ± 1 % ◆ Heizwert ± 1,5 %  vom Messbereichsendwert
<b>Gasverbrauch</b>	= 60-80 l/h in Abhängigkeit vom gewählten Messbereich
<b>Merkmale</b>	◆ manuelle / automatische Kalibrierung ◆ Eingangsdruck 8 - 20 mbar ◆ Sicherheitseinrichtung ansprechend bei Gas- bzw. Kühlluftmangel und bei Stromausfall ◆ automatische Zündeinrichtung ◆ Wandaufbaueinheit 600 x 600 x 210 mm (H x B x T) ◆ Lackierung RAL 7032
<b>Schutzart</b>	◆ Wandaufbaueinheit IP 10 ◆ Gebläse IP 54 nach DIN 40050 / IEC 529
<b>Gewicht</b>	◆ Messgerät ca. 40 kg ◆ Gebläse ca. 22 kg
<b>Energieversorgung</b>	115 / 230 V 50 (60) Hz
<b>Anschlüsse</b>	Messgas / Prüfgas: Schneidringverschraubung 8 mm Ø
<b>Einsatzbereiche</b>	Gasturbinen, Klär-, Bio- und Deponiegas, Erdgasspeicher, Raffinerien, Chemische Industrie, Hochofenbetriebe, Kokereien, Stahlwerke, Kraftwerke, Glas- und Porzellanwerke

## Technical Datas

<b>Type of measuring unit</b>	WI
<b>Measuring gas</b>	all flammable gases
<b>Kind of measurement</b>	Net calorific value or wobbe index or energy heat flow
<b>Measuring range</b>	free eligible (factory setting) 50-100 % from the final value of the measuring range, example: 50-100 (MJ/m <sup>3</sup> )
<b>Unit of measurement</b>	free eligible (factory setting) MJ/m <sup>3</sup> * kWh/m <sup>3</sup> * Mcal/m <sup>3</sup>
<b>Output signal</b>	◆ 0 ... 20 mA (Load: ≤ 500 Ω) ◆ 4 ... 20 mA (Load: ≤ 500 Ω)
<b>Digital display</b>	3 1/2 digits LE-Display
<b>Runtime performance</b>	◆ Response time: 3 s ◆ T <sub>50</sub> -time: 8 s ◆ T <sub>90</sub> -time: ~30 s after of the measuring gas in the measuring unit dependent on the selected measuring range ◆ Warm-up period: 30 min
<b>Measuring accuracy</b>	◆ Wobbe-Index ± 1 % ◆ Energy heat flow ± 1 % ◆ Net calorific value ± 1,5 %  from the final value of the measuring range
<b>Gas consumption</b>	= 60-80 l/h dependent on the selected measuring range
<b>Features</b>	◆ manual / automatic calibration ◆ input pressure 8 - 20 mbar ◆ safety device appealing by shortage of gas or cooling air and by power failure ◆ automatic ignition device ◆ Wall-mounting case 600 x 600 x 210 mm ( H X B x D) ◆ Painting RAL 7032
<b>Degree of protection</b>	◆ Wall-mounting case IP 10 ◆ Fan unit IP 54 according DIN 40050 / IEC 529
<b>Weights</b>	◆ Measuring unit approx. 40 kg ◆ Fan unit approx. 22 kg
<b>Power supply</b>	115 / 230 V 50 (60) Hz
<b>Connections</b>	Measuring gas / test gas: Cutting ring connector 8 mm Ø
<b>Applications</b>	Gas turbines, bio- and landfill gas, natural gas caverns, Raffineries, chemical plants, blast-furnace plants, coke oven plants, steel factories, power plants, glas and porcelaine factories

# Reineke



Ein Unternehmen mit Tradition und Zukunft  
A company with tradition and a future

Gasmessgerät, RBM 2000  
Gas measuring device, RBM 2000

ISO 9001  
Qualität



D-44807 Bochum · Von-Ebner-Eschenbach-Str. 5  
Internet: [www.reineke-online.com](http://www.reineke-online.com)

## Reineke

Telefon 02 34 / 95 95-0 · Telefax 02 34 / 95 95-200  
e-mail: [reinekefuchs@t-online.de](mailto:reinekefuchs@t-online.de)

Meß- und Regeltechnik GmbH

## Technische Daten

<b>Messgerätetyp</b>	RBM 2000
<b>Messgas</b>	alle brennbaren Gase
<b>Messgröße</b>	Heizwert oder Brennwert, Wobbe-Index, Dichte und Mindestluftbedarf
<b>Messbereich</b>	frei wählbar (wird werksseitig eingestellt) Messung von 3 - 100 MJ
<b>Einheit</b>	frei wählbar (wird werksseitig eingestellt) MJ/m <sup>3</sup> * kWh/m <sup>3</sup> * Mcal/m <sup>3</sup>
<b>Ausgangssignal</b>	<ul style="list-style-type: none"> <li>◆ 0 ... 20 mA (Bürde: ≤ 500 Ω)</li> <li>◆ 4 ... 20 mA (Bürde: ≤ 500 Ω)</li> </ul> je Messgröße, galvanisch getrennt
<b>Anzeige</b>	LC-Display, 16 Zeilen, 40 Zeichen
<b>Zeitverhalten</b>	<ul style="list-style-type: none"> <li>◆ Ansprechzeit: 1 s</li> <li>◆ T<sub>50</sub> - Zeit: 4 s</li> <li>◆ T<sub>90</sub> - Zeit: ~10 s</li> </ul> nach Eintritt des Messgases in das Messgerät in Abhängigkeit vom gewählten Messbereich <ul style="list-style-type: none"> <li>◆ Anwärmszeit: 30 min</li> </ul>
<b>Messgenauigkeit</b>	<ul style="list-style-type: none"> <li>◆ Wobbe-Index &lt; 1 %</li> <li>◆ Dichte &lt; 1 %</li> <li>◆ Heizwert &lt; 1 %</li> <li>◆ Mindestluftbedarf &lt; 1 %</li> </ul> bei Erdgasen vom Messwert < 0,7 %
<b>Gasverbrauch</b>	= 80 - 150 l/h in Abhängigkeit vom gewählten Messbereich
<b>Merkmale</b>	<ul style="list-style-type: none"> <li>◆ manuelle / automatische Kalibrierung</li> <li>◆ Eingangsdruck 20 - 30 mbar</li> <li>◆ Sicherheitseinrichtung ansprechend bei Gas- bzw. Kühlluftmangel und bei Stromausfall</li> <li>◆ Flammenüberwachung</li> <li>◆ automatische Zündeinrichtung</li> <li>◆ Fehlerdiagnose</li> <li>◆ Wandaufbaugehäuse 600 x 760 x 210 mm (H x B x T)</li> <li>◆ Lackierung RAL 7032</li> <li>◆ hoch präzise Dichtemesskammer</li> <li>◆ Luftanschluß durch Kühlluftgebläse oder Druckluft</li> </ul>
<b>Schutzart</b>	<ul style="list-style-type: none"> <li>◆ Wandaufbaugehäuse IP 10</li> <li>◆ Gebläse IP 54 nach DIN 40050 / IEC 529</li> </ul>
<b>Gewicht</b>	<ul style="list-style-type: none"> <li>◆ Messgerät ca. 70 kg</li> <li>◆ Gebläse ca. 22 kg</li> </ul>
<b>Energieversorgung</b>	115 / 230 V 50 (60) Hz
<b>Anschlüsse</b>	Messgas / Prüfgas: Schneidringverschraubung 8 mm Ø
<b>Einsatzbereiche</b>	Gasturbinen, Klär-, Bio- u. Deponiegas, Erdgasspeicher, Raffinerien, Chem. Industrie, Hochofenbetriebe, Kokereien, Stahlwerke, Kraftwerke, Glas- und Porzellanwerke

## Technical Datas

<b>Type of measuring unit</b>	RBM 2000
<b>Measuring gas</b>	all flammable gases
<b>Kind of measurement</b>	Net or gross calorific value, wobbe index, density and minimum air requirement
<b>Measuring range</b>	free eligible (factory setting) Measurement between 3 - 100 MJ
<b>Unit of measurement</b>	free eligible (factory setting) MJ/m <sup>3</sup> * kWh/m <sup>3</sup> * Mcal/m <sup>3</sup>
<b>Output signal</b>	<ul style="list-style-type: none"> <li>◆ 0 ... 20 mA (Load: ≤ 500 Ω)</li> <li>◆ 4 ... 20 mA (Load: ≤ 500 Ω)</li> </ul> per measuring signal, galvanic isolated
<b>Display</b>	LC-Display, 16 lines per 40 characters
<b>Runtime performance</b>	<ul style="list-style-type: none"> <li>◆ Response time: 1 s</li> <li>◆ T<sub>50</sub> - time: 4 s</li> <li>◆ T<sub>90</sub> - time: ~10 s</li> </ul> after entry of the measuring gas in the measuring unit dependent on the selected measuring range <ul style="list-style-type: none"> <li>◆ Warm-up period: 30 min</li> </ul>
<b>Measuring accuracy</b>	<ul style="list-style-type: none"> <li>◆ Wobbe-Index &lt; 1 %</li> <li>◆ Density &lt; 1 %</li> <li>◆ Net calorific value &lt; 1 %</li> <li>◆ Minimum air requirement &lt; 1 %</li> </ul> measured for natural gases from measured value < 0,7 %
<b>Gas consumption</b>	= 80 - 150 l/h dependent on the selected measuring range
<b>Features</b>	<ul style="list-style-type: none"> <li>◆ manual / automatic calibration</li> <li>◆ Input pressure 20 - 30 mbar</li> <li>◆ Safety device appealing by shortage of gas or cooling air and by power failure</li> <li>◆ Flame control</li> <li>◆ Automatic ignition device</li> <li>◆ Error indication</li> <li>◆ Wall-mounting case 600 x 760 x 210 mm ( H X B x D)</li> <li>◆ Painting RAL 7032</li> <li>◆ High precision density measuring cell</li> <li>◆ Air supply with fan unit or pressurized air</li> </ul>
<b>Degree of protection</b>	<ul style="list-style-type: none"> <li>◆ Wall-mounting case IP 10</li> <li>◆ Fan unit IP 54 according DIN 40050 / IEC 529</li> </ul>
<b>Weights</b>	<ul style="list-style-type: none"> <li>◆ Measuring unit approx. 70 kg</li> <li>◆ Fan unit approx. 22 kg</li> </ul>
<b>Power supply</b>	115 / 230 V 50 (60) Hz
<b>Connections</b>	Measuring gas / test gas: Cutting ring connector 8 mm Ø
<b>Applications</b>	Gas turbines, bio- and landfill gas, natural gas caverns, raffineries, chemical plants, blast-furnace plants, coke oven plants, steel factories, power plants, glas and porcelaine factories

# GAS ANALYSER

## Content

Content .....	1
1 Introduction .....	2
2 Applications .....	2
2.1 Gas characteristic quantities .....	3
3 Gas Analyser – Type RBM .....	5
3.1 Advantage of RBM2000 .....	6
4 Gas Analyser – Type WI .....	9
5 Principles of operation .....	9
5.1 Operating method .....	9
5.2 Operating method Wobbe Index Instrument .....	10
5.3 Operating method Net Calorific Value Instrument .....	10
6 Explosion proof design .....	13
7 Gas Analyser Data Sheet .....	16
8 Major References .....	17

**REINEKE MESS - UND REGELTECHNIK GMBH**  
Von-Ebner-Eschenbach-Str. 5, D-44807 Bochum, Germany  
Tel. +49 (0)234 9595-0, Fax +49 (0)234 9595-200  
E-mail: [reinekefuchs@t-online.de](mailto:reinekefuchs@t-online.de), Internet: [www.reineke-online.com](http://www.reineke-online.com)



## 1 Introduction

Reineke Meß- und Regeltechnik GmbH, established manufacturer since 1912 of gas analysers for high and low calorific value (BTU), Wobbe-Index, density and minimum air consumption, offers herewith the latest edition of their gas analysers.

Environmental regulations and cost effective energy consumption demand high sophisticate analysers for end users in a wide range of industries.

Reineke's gas analysers are supplied with fast response, high accuracy and repeatability, low maintenance cost and easy calibration one of the most reliable gas analyser for several applications in the general gas industry.

The products are inspected by TÜV (the German Inspection Authority) or other International inspection parties and Reineke is certified in accordance with DIN EN ISO 9001.

## 2 Applications

Reineke Meß- und Regeltechnik GmbH has their analysers world-wide in application:

- Gasturbines
- Sewage, bio- and landfill gas
- Natural gas caverns
- Incineration plants
- Cogeneration power plants
- LPG / Air mixing plants
- Refineries –tail gas mixing
- (Petro) Chemical plants
- Blast-furnace and cokery plants
- Glass and porcelain factories (temperature control)
- Mixing and/or blending of gas streams with variable compounds
- Fuel gas control for burners and ovens

## 2.1 Gas characteristic quantities

In the following the characteristic quantities to be determined for these measuring instruments are explained. The description part is taken from the corresponding valid standards.

### Net Calorific Value $H_{u,n}$ ( $H_{iv,n}$ )

The net calorific value of a gas is the quantity of heat (reaction enthalpy), which is released with the complete burning of a dry gas with oxygen of  $\text{CO}_2$  and  $\text{H}_2\text{O}$  (vaporous) when the reaction products are brought back to the original conditions of +273,15 K and 1013,25 mbar

( $H_{iv,n}$  = inferior calorific value = volume related net calorific value)

### Gross Calorific Value $H_{o,n}$ ( $H_{sv,n}$ )

The gross calorific value of a gas is the quantity of heat (reaction enthalpy), which is released with the complete burning of a dry gas with oxygen of  $\text{CO}_2$  and  $\text{H}_2\text{O}$  (liquid) when the reaction products are brought back to the original conditions of +273,15 K and 1013,25 mbar

( $H_{sv,n}$  = superior calorific value = volume related gross calorific value)

### Relative density, $d$ (special gravity)

The relative density is the quotient of the dry gas's density and of the dry air (tr) in the same atmospheric pressure and temperature conditions

$$d = \frac{P_{\text{gas, n}}}{P_{\text{dry air, n}}}$$

In the case the meaning of index  $n$  relates to the normal conditions, which means  $T = 273,15 \text{ K}$  and  $p = 1,01325 \text{ bar}$ .

### Wobbe-Index, $W_{u,n}$ ( $W_{iv,n}$ ) or $W_{o,n}$ ( $W_{sv,n}$ )

The Wobbe-Index is the parameter for the thermal load. Varying compounds of fuel gases, which have an equal Wobbe Index and are burnt under the same jet and/or burning pressure, which gives the burner the same thermal load.



The lower Wobbe-Index is the quotient from the net-calorific value and from the square root of the relative density of the gas to be measured.

$$\text{Wobbe Index} = \frac{\text{Net calorific value}}{\sqrt{\text{relative density}}} \qquad \text{Wu,n} = \frac{\text{Hu,n}}{\sqrt{d}}$$

The upper Wobbe-Index is the quotient from the gross calorific value and from the square root of the relative density of the gas to be measured.

$$\text{Wobbe Index} = \frac{\text{Gross calorific value}}{\sqrt{\text{relative density}}} \qquad \text{Wo,n} = \frac{\text{Ho,n}}{\sqrt{d}}$$

#### Minimum Air Requirement, $L_{\min}$

The minimum air requirement is the air volume necessary for complete (stoichiometric) burning. Complete burning means that the supplied gas to the burner is fully burnt. This value is used in the burner control units where the gas / air relation is not controlled by the Wobbe-Index, but mainly controlled directly with the relation

$$\frac{L_{\min}}{\sqrt{d}}$$

(Note: The calorific value  $H_{u,n}$  is dependent on  $L_{\min}$  and on the density).

### 3 Gas Analyser – Type RBM

Analysing combustion characteristics, two measuring principles are used.

Rest oxygen particles in the exhaust gas are measured and the frequency of the gas when flowing through a labial pipe (also known as organ pipe) is measured.

Analysing, during the process, fuel gas quantity (of ca. 100 l/h) is flowing through the analyser. Due this process the gas streams through a labial pipe and effects a vibration, the frequency of which depends on the speed of sound of the gas. The frequency is recorded by a microphone and converted in an analogue wiring to a voltage signal. Combined with the (also) measured gas temperature, the density is calculated by way of following interrelation:

$$\rho_{n.} = K \cdot \frac{T_{gas}}{f_{gas}^2}$$

The constant K (proportionate factor) is here determined by calibration.

Fuel gas is premixed with an air stream (fuel air) and is burnt completely in a combustion chamber. On the top of the combustion chamber is a ZrO<sub>2</sub> (lambda) sensor which measures the rest oxygen concentration in the exhaust gas.

The minimum air requirement of the fuel gas is taken from the oxygen balance surrounding the burner together with the measured density while the fuel air and fuel gas volume stream are constant.

Calorific value and Wobbe Index of the fuel gas are calculated from a correlation of density and minimum air requirement ratio. In this case there is a choice of several different correlations, for power gases (for example butane/air mixtures), natural gases, coke-oven gases and lean gases (blast furnace gas), which are operated by the plant.

The output signals are then directed for further processing to a programmable measuring and control unit. Combustion characteristics are calculated and converted in an analogue output signal (4 - 20 mA for each value).

This electronic unit controls the measuring device. In case of a lack of air or gas failure the gas supply is immediately shut off for safety duties.

The fuel gas/air mixture in the burner is automatically ignited by the automatic ignition device.

The required adjustments can be easily carried out over the front keyboard. The entire programming is integrated on a storable EPROM.

This offers the advantage of being able to constantly update the programming or to optimize the measurement for every gas which should be measured.



### 3.1 Advantage of RBM2000

Please notice this list to evaluate the benefits of the Reineke gas analyzer type RBM 2000:

- Very short reponse time
- High accuracy for density, calorific value and wobbe-index
- Direct measurement of density
- Error indication on display
- Low price
- Low maintenance, easy construction
- Software update possible
- Ambient Temperatur compensation
- Very good stability for Zero/Span drift

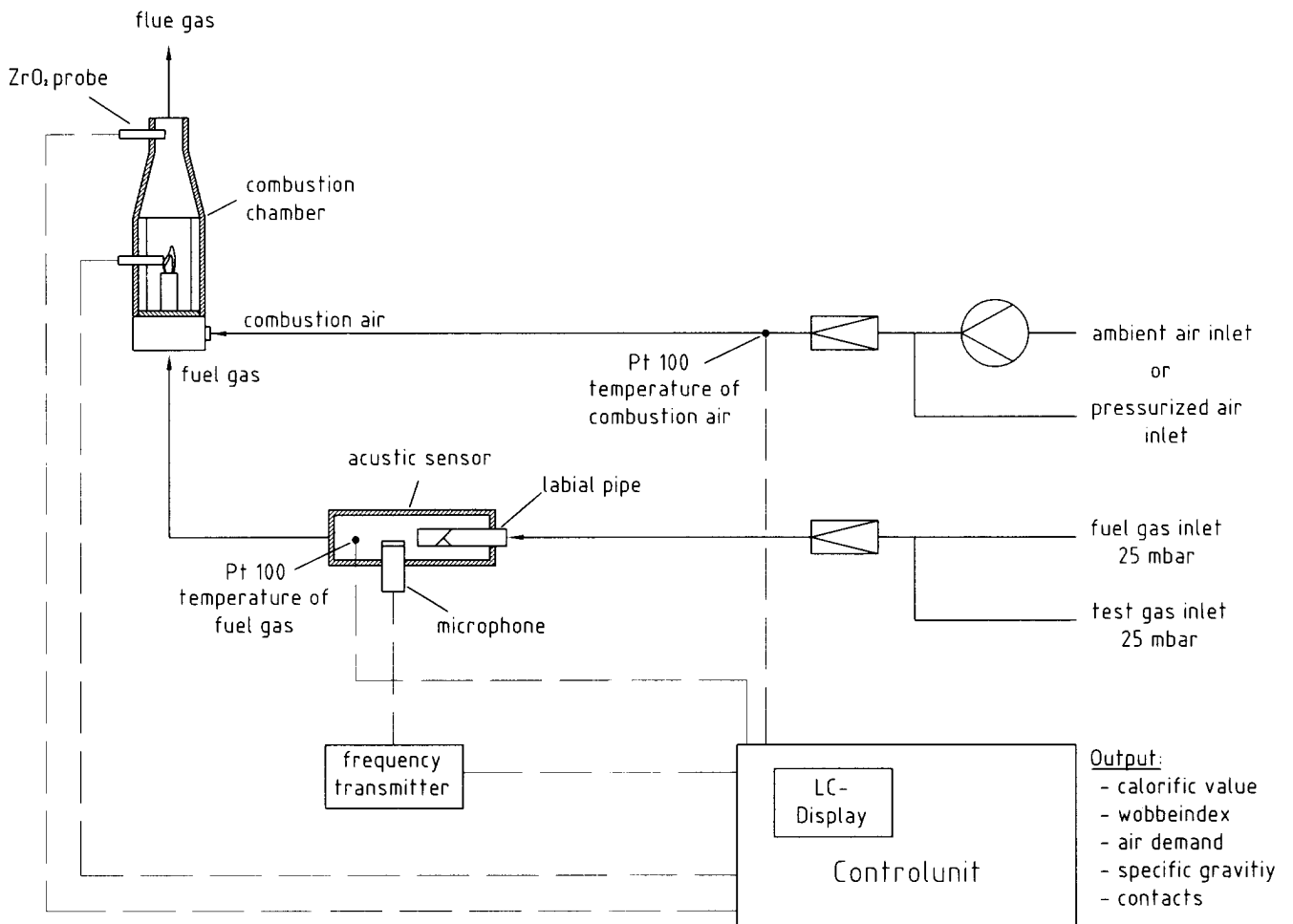

Flow diagram Gas Analyser RBM 2000

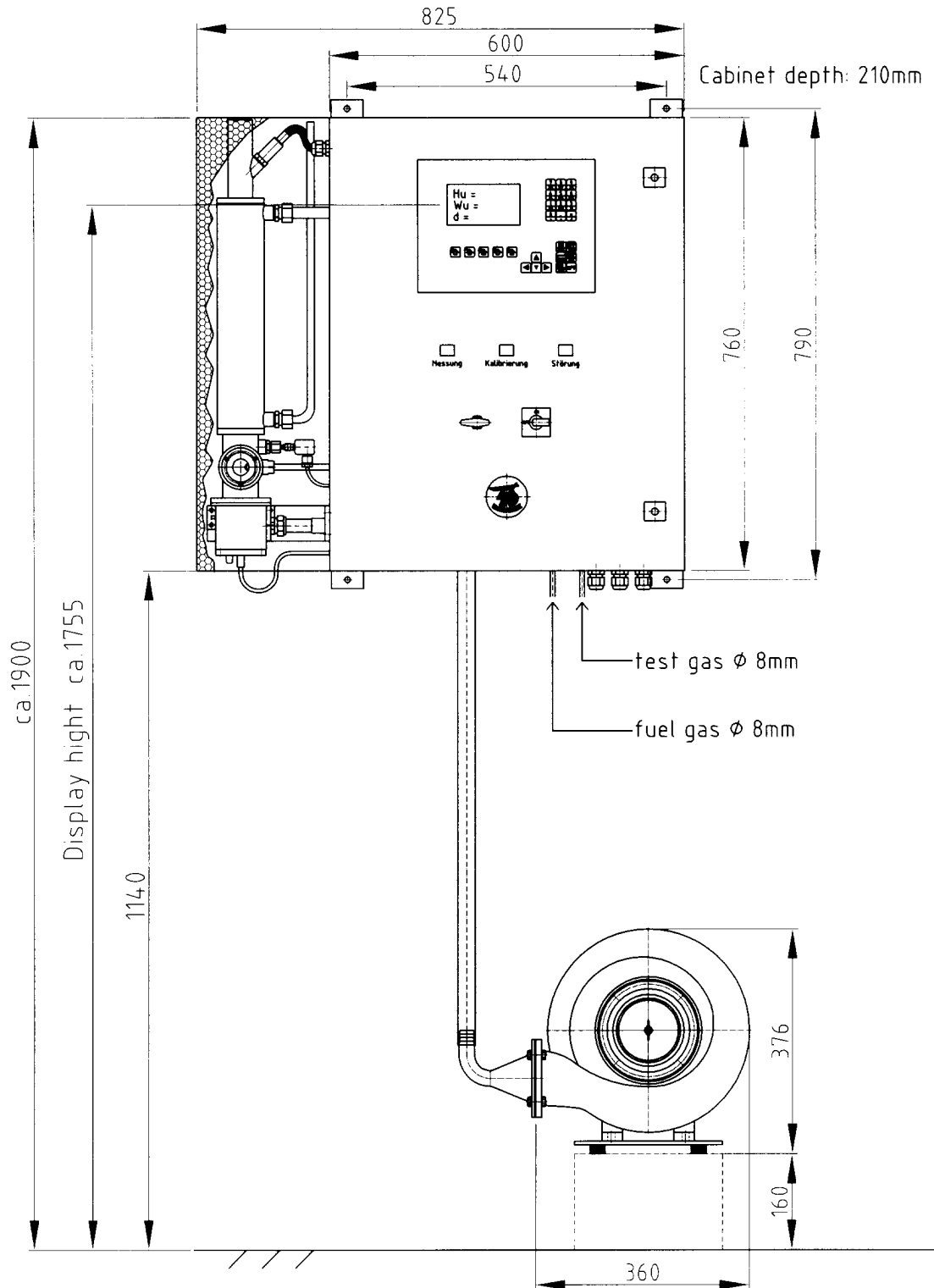

Gas Analyser RBM 2000 with air fan

## Gas Analyser – Type WI

Type: WI / W	manual calibration
Type: WI / WA	with microprocessor controlled automatic calibration device (additional) possibility of manual calibration
Type: WI / H	manual calibration
Type: WI / HA	with microprocessor controlled automatic calibration device (additional) possibility of manual calibration

## 5 Principles of operation

The principle of the gas measuring unit is based on the stability of the temperature of the exhaust gas in a proportional band of 5° C burning a gas by air mixing.

As the burning temperature changes the quality of the gas a regulated amount of cooling air has to be added. In this manner the amount of cooling air is proportional to the measured value.

### 5.1 Operating method

The gas to be measured flows through an orifice into the burner and burns at the burner stop. The primary and secondary combustion air is taken from the cooling air delivered by the fan via the air control valve and the orifice into the chimney.

The hot exhaust gas and the cooling air are mixed in the mixer and heat up the expansion tube, acting as a temperature sensor and bled to atmosphere through the openings in the exhaust gas tube.

By changing the length of the expansion tube the lever is moved and the air escaping control jet is covered more or less. The control jet and the throttle are a cascade, whose pressure controls the position of the air control valve and so the amount of cooling air. A different pressure is built up consequently in front of the air orifice, which is proportional to the square of the measured value which is the output signal, too. The indicator shows this pressure and can be used for testing the gas pressure after change over of the three-way valve.



## 5.2 Operating method Wobbe Index Instrument

The gas to be measured is conducted to the burner via the precision gas pressure governor at constant pressure (3,5 mbar  $\pm$  0,03 mbar respectively 0,05 psi  $\pm$  0,0004psi). The burner capacity varies with the net (low) calorific value  $H_u$  and the specific gravity  $d$  and so with the Wobbe Index. The output signal is the pressure in front of the air orifice, which is proportional to the square of the Wobbe Index.

## 5.3 Operating method Net Calorific Value Instrument

The gas to be measured is conducted via the precision gas pressure governor to the gas pump, which delivers a constant gas volume (independent from the gas density) to the burner. The burner capacity varies consequently only with the net calorific value.

If the volume flow of the gas is constant then the heat efficiency of the burner is proportional to the net calorific value according the relation:

$$\text{Heat efficiency burner} = \text{Volume flow} \times \text{Net calorific value}$$

The output signal is the pressure in front of the air orifice, which is proportional to the square of the net calorific value.

**GAS ANALYSER**

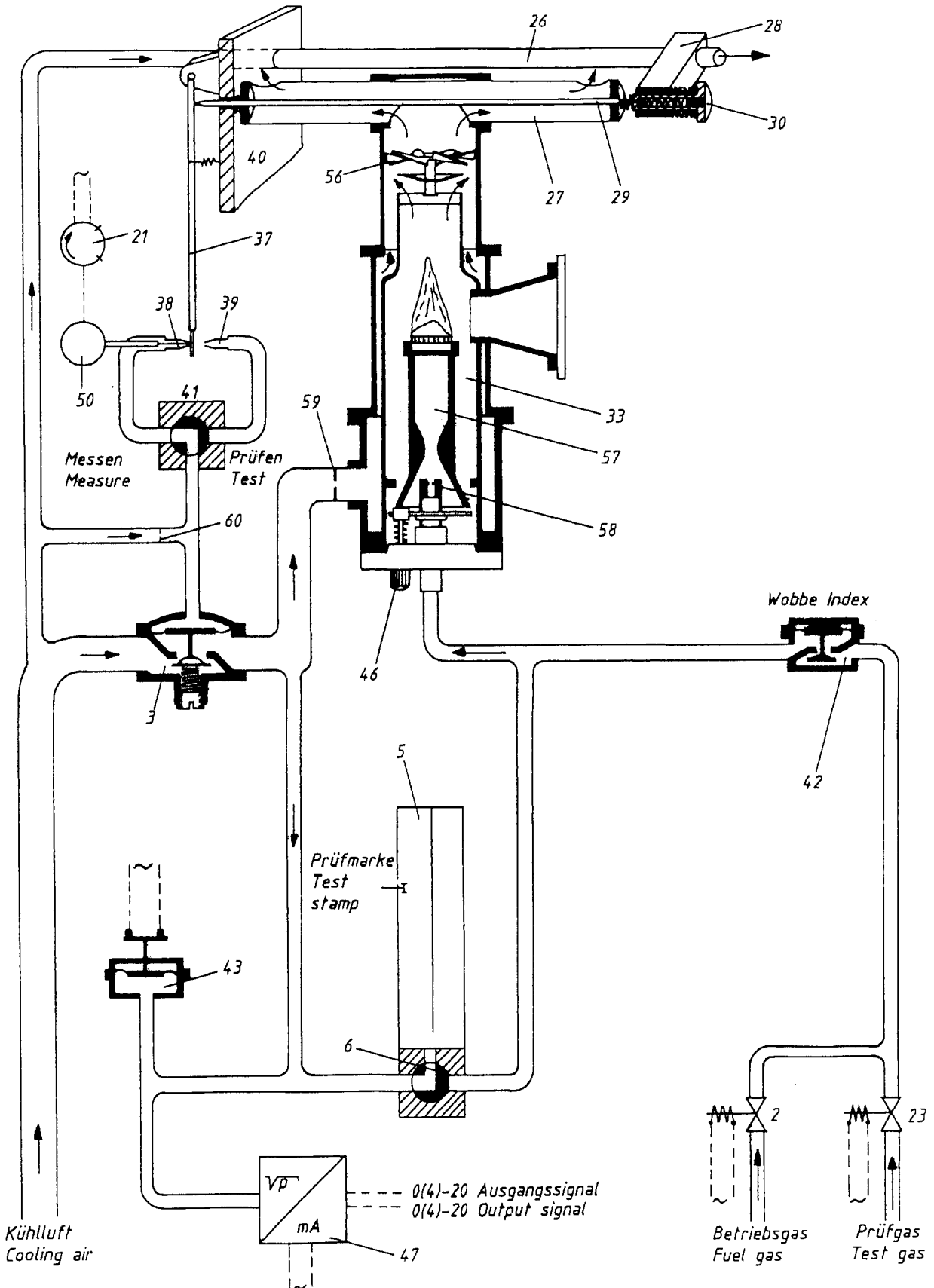

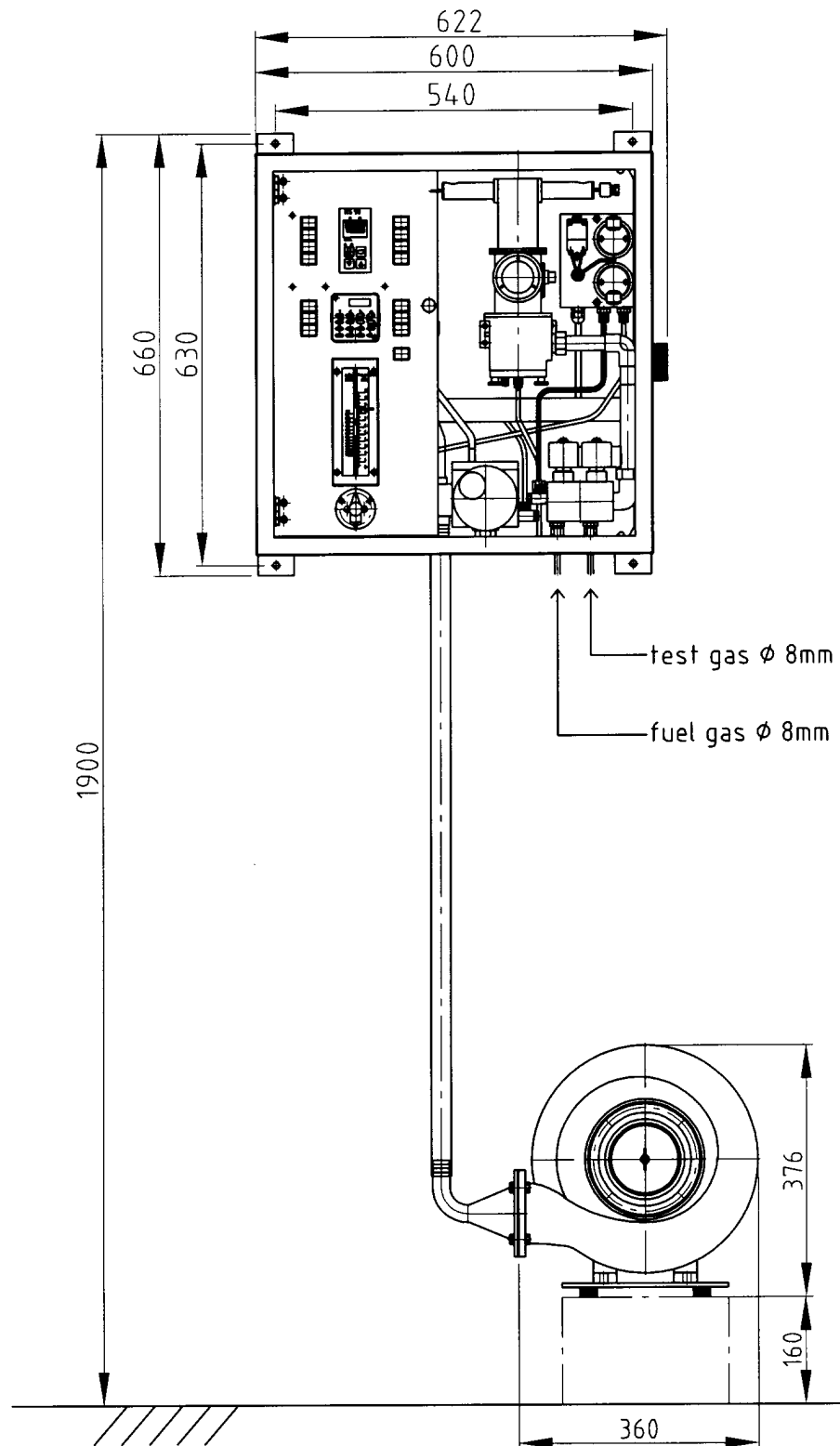

Gas Analyser WI for Wobbe-Index or net calorific value

## 6 Explosion proof design

Reineke offers two solutions for applications in hazardous area.

1. Explosion proof analyser house, constructed of cast iron material and equipped with flame in the air inlet and exhaust gas outlet.  
**Class. 1. Div. I: Suitable for gas analyser type WI only**
2. Explosion proof cabinet with purge system. The gas analyser is installed in a steel sheet or polyester cabinet equipped with flame arrester in air inlet and exhaust gas outlet. The cabinet inside area is continuous in over pressure by an air or nitrogen purge system.  
**Class.1. Div. II: Suitable for gas analyser types RBM and WI**

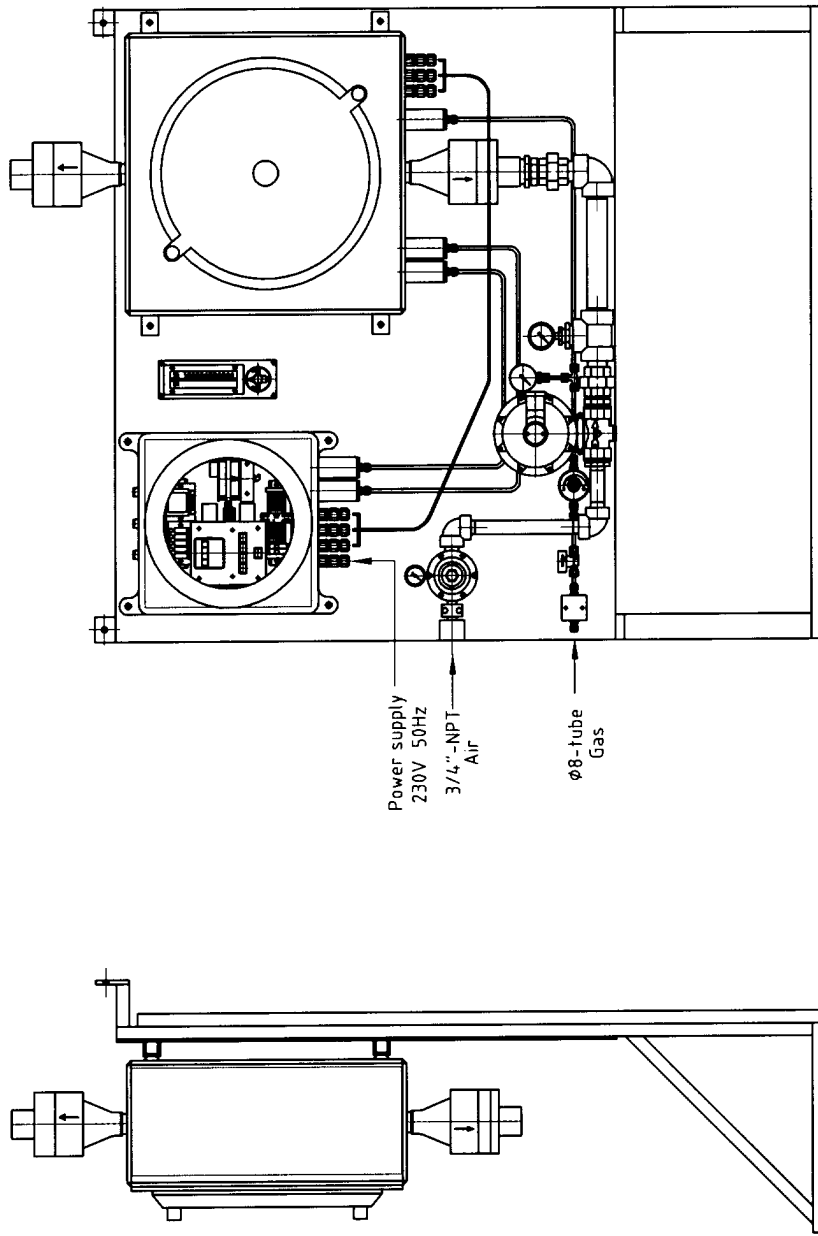

Class.1. Div. 1 WI-Analyser

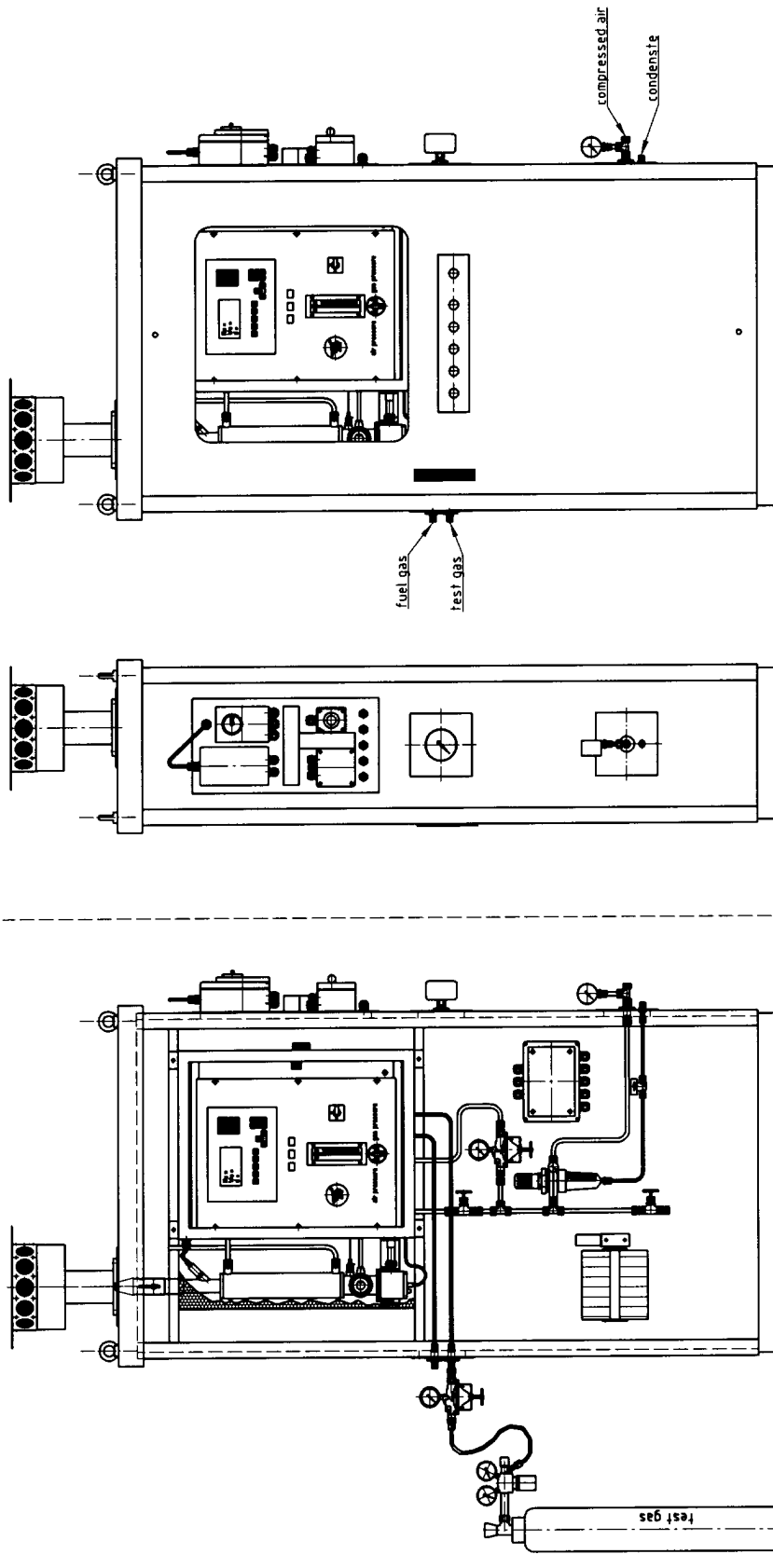

Analyser cabinet with purge air system



## 8 Major References

ABB	Germany/France/Sweden
Ahmsa	Mexico
Altos Hornos Steel Works	Mexico
Ansaldo Turbines	Italy
Baoshan Steel	China
BASF AG	Germany
BAYER AG	Germany
BEB	Germany
Bells Controls	India
BP Cologne (EC-Erdoelchemie)	Germany
British Steel	England
CCT	Greece
Cockerill Sambre	Belgium
Distrigaz	Belgium
Dow Chemicals	Netherlands
Gasunie	Netherlands
Gaz de France	France
General Electrics (Nuovo Pignone)	Italy
Huta Sendzimir Steel Work	Poland
Hüls AG	Germany
Huettenwerke Katowice	Poland
Italimpianti	Germany/Italy
Kawasaki Heavy Industries	Japan
Kosice Steel	Slowakei
Lurgi Engineering	Germany
Maerz Ofenbau	Switzerland
Mitsubishi Heavy Industries	Japan
Orlen Plock	Poland
PEMEX	Mexico
Preussag	Germany
Promatis	Russia
Rautaruukki Oy	Finland
Rourkela Steel Plant	India
Saldanha Steel	South Africa
Shell	Netherland
SSAB Öxelösund	Sweden
Stein Heurty	France
Tata Steel Industry	India
Thyssengas	Germany
Thyssen Krupp	Germany
Veba Oil	Germany
Voest Alpine	Austria
Volkswagen AG	Germany
Wintershall	Germany